



INSTRUCTION MANUAL

# SRT/STD

Square Root Transmitter

152-701-00D

April 2016

---

---

## INTRODUCTION

### 1.1 SCOPE OF MANUAL

This manual contains operating and maintenance information on the two wire SRT transmitter, manufactured by MOORE INDUSTRIES INC., Sepulveda, California. The manual consists of six sections as follows:

**Section 1, General Information**, covers equipment function, physical appearance, specifications and options available for the unit. The introduction also explains the MOORE INDUSTRIES model numbering system.

**Section 2, Installation and Calibration**, provides all the information necessary to calibrate the unit before installation. This section contains a list of the tools necessary for calibrating the equipment, and illustrates the test setups essential to perform the task.

**Section 3, Operation**, supplies all the information needed to install and operate the equipment. The section contains figures that specify the installation requirements for the units, and text that informs the user on recommended wiring practices for the equipment and defines the electrical connections for each unit regardless of physical modifications.

**Section 4, Theory of Operation**, gives the maintenance personnel a detailed explanation of the internal function of the unit. The circuit theory is based on a block diagram that shows the functional elements of the unit. Each element's operation is then described, first in relation to the other elements, then independently, where its major components, use, and purpose are described.

**Section 5, Maintenance**, offers complete disassembly procedures for all unit configurations available. Troubleshooting information is also provided in this section as well as component replacement techniques to aid the technician in the repair of the equipment.

**Section 6, Unit Documentation**, acquaints the user with the MOORE INDUSTRIES' computerized parts listing and identification system. The section also provides a recommended spare parts list. All schematics and parts assembly drawings referred to in the text are located in the back of Section 6.

### 1.2 PURPOSE OF EQUIPMENT

The Square Root Transmitter (SRT) is used in process control systems to perform the computation:

$$I_{\text{output}} = K \sqrt{(I_{\text{input}} - I_{\text{input min}})}$$

The input may be any standard DC current or voltage proportional to the quantity whose square root is desired. The output is a standard DC current or voltage proportional to the square root of the span (actual input with live zero modified) of the applied input signal.

### 1.3 GENERAL DESCRIPTION

The input signal is applied to an input amplifier whose feedback is controlled by solid-state switches. The amplitude of the amplified input signal is compared with that of an internally-generated ramp in a comparator that provides drive to the switches. This method of generating the drive to the switches and the arrangement of these switches cause the amplifier to produce an output proportional to the square root of the span of the input signal. This output is linearly amplified to produce an output likewise proportional to the square root of the input-signal span.

### 1.4 PHYSICAL DESCRIPTION

The SRT is available in several different physical configurations. In general, the unit consists of two circuit boards, with one small board (PC2) mounted on a main board (PC1). The small board contains voltage regulators and a rectifier, and the main board holds all the signal-processing and signal-generating circuits. The boards are enclosed in a protective housing, and the entire assembly may be installed in a number of ways. A bracket (supplied when specified in order) may be used to mount the assembly. For hazardous environments, an explosion-proof housing with a base containing up to four threaded hubs for wiring can be supplied. Also available is an enclosure that is oil-tight and dust-tight and another that is water-tight. Although the printed-circuit board assembly is electrically identical regardless of the physical configuration and mounting method, the external electrical connections may be made to different terminals on the terminal block in the various versions of the unit. Specific details for making electrical connections are given in Section 2, Calibration Procedures.

The specifications of the SRT are given in Table 1-1.

**TABLE 1-1 UNIT SPECIFICATIONS**

**INPUT:** Squared current or voltages from  $\Delta P$  transmitters

**Current:**

- 1-5 mA into 200 ohms nominal
- 4-20 mA into 50 ohms nominal
- 10-50 mA into 20 ohms nominal

**Voltage:**

- 0-5V, 1-5 V standard
- 100K ohm load
- Other voltages optional

**FRONT PANEL ADJUSTMENTS:** Adjustable with multiturn potentiometers

**Span:** With full scale input, adjusts output to  $100\% \pm 20\%$  of selected output span

**Zero:** With minimum input, adjusts output to  $0\% \pm 10\%$  of selected output span

**Input Zero:** Compensates for input live zero offset for specified zero percent input

**OUTPUT:** Operational amplifier feedback current source; output limited to 150% of maximum output range value

**Current:**

- 1-55 mA into 0-4800 ohm load
- 4-20 mA into 0-1200 ohm load
- 10-50 mA into 0-480 ohm load

**Voltage:** 1-5 VDC standard into 20K ohms minimum

**Ripple:** 10 mV P/P at maximum span and maximum load resistance

**Load Effect:**  $\pm 0.01\%$  of span from 0 to maximum load resistance (current output)

**PERFORMANCE:**

**Calibration Capability:**  $+ 0.25\%$  of span (linearity and repeatability)

**Ambient Temperature:**

- Range:  $-20^{\circ}\text{F}$  to  $+180^{\circ}\text{F}$  ( $-29^{\circ}\text{C}$  to  $+82^{\circ}\text{C}$ )
- Effect:  $\pm 0.01\%$  /  $^{\circ}\text{F}$  over above range

**Frequency Response:** 15 Hz (3-dB point)

**Isolation:** Voltage output units have input negative side common to output negative side. Current output models have output negative side elevated above input negative side. Power input isolation is maintained on both AC and DC powered units.

**POWER INPUT:**

- 24 VDC, 45 VDC,  $\pm 10\%$
- 117 VAC, 220 VAC, 240 VAC, 50/60 Hz,  $\pm 10\%$
- 5 watts nominal

**Line Voltage Effect:** AC or DC:  $\pm 0.005\%$  / 1% line change

**OPTIONS:**

- TX Two-wire transmitter excitation 35 VDC @ 25 mA output to two-wire field transmitter, 4-20 mA only

**HOUSING:**

**Housing Options:**

- STD Standard enclosure as illustrated
- AB Angle bracket mounting
- CP Conduit plate for use with standard units
- EX Explosion-proof enclosure, Single Unit — Div. 1
- GP General purpose enclosure, Single Unit — NEMA 1
- OT Oil-tight enclosure, Single Unit — NEMA 12
- PC Plug-in card — See Data Sheet 350-710-01
- PM Panel mount enclosure
- WT Water-tight enclosure, Single Unit — NEMA 4

**CERTIFICATION:** Canadian Standards Association

**WEIGHT:** Approximately 2 lbs. (908 grams)

**ORDERING INFORMATION:** Specify the following

1. Input — range of voltage or current
2. Output — span of voltage or current
3. Power input
4. Options
5. Housing

**SAMPLE MODEL NUMBER**

SRT/4-20MA/4-20MA/117AC/TX/STD

## 1.5 MODEL NUMBERING SYSTEM

Model Numbers describe an instrument's type, functional range, and features. If all accompanying documentation of a unit should be missing, one can still "translate" the Model Number back into a working description of the unit by using the information in this paragraph as a reference. Table 1-2 explains the model numbering system.

**TABLE 1-2 MODEL NUMBERING SYSTEM**

### BASIC EXAMPLE:

SRT, 4-20 mA input, 1-5 VDC output, 117 VAC power

**SRT/ 4-20MA/ 1-5VDC/ 117AC**

### BASIC INSTRUMENT TYPE:

SRT indicates Square Root Transmitter

### INPUT RANGE:

*Numbers:* Minimum and maximum nominal input range, generally an industry standard

*SC:* Selectable Current (i.e., input current range selectable with one of several resistors supplied for this purpose)

### OUTPUT RANGE:

*Numbers:* Minimum and maximum nominal output range, generally an industry standard

*SC:* Selectable Current (i.e., output current range selectable with one of several resistors supplied for this purpose)

### POWER INPUT:

*DC:* DC power, 24 VDC  $\pm$  10% unless stated otherwise, e.g., 45 VDC

*AC:* AC power, 117 VAC  $\pm$  10% unless stated otherwise, e.g., 240 VAC

### INPUT AND OUTPUT ABBREVIATIONS:

MA = milliamperes      V = volts

## 2.1 GENERAL INSTALLATION INFORMATION

Installation, in general, consists of calibration (when required), mechanical mounting, and making the electrical connections to the unit. The necessary procedures are described in paragraph 2.3 and those following that paragraph. Before actually calibrating the unit, however, the reader should first become familiar with the type of controls on the unit and tools (if any) required for adjustment; these are described in paragraph 2.2.

## 2.2 CONTROLS

Several types of controls are provided on standard Moore Industries products. They have been carefully selected to fulfill the necessary electrical requirements and also provide optimum ease of adjustment by the user.

All external controls require a screwdriver to adjust. The units have multi-turn potentiometers that are adjusted with a blade screwdriver NOT MORE THAN 0.1 INCH (2.54 mm) WIDE. USE OF A WIDER BLADE MAY PERMANENTLY DAMAGE THE POTENTIOMETER MOUNTING. This type of potentiometer usually requires 20 turns of the shaft to move the wiper from one end of its range to the other. It is equipped with a slip clutch at either end of its travel to prevent damage if it is turned beyond the wiper stop. Usually a slight change in feel will be noticed when the clutch is slipping; however, if this change is not observed, one can be certain of reaching either end by turning the shaft 20 turns in the desired direction. Controls are connected so turning the shaft clockwise increases the quantity or makes it more positive, and turning the shaft counterclockwise has the opposite effect.

When present, internal adjustable controls are single-turn potentiometers that require a screwdriver with a blade not more than 0.1 inch (2.54 mm) wide. Since these devices do not have slip clutches, care must be used to avoid overtorquing them.

## 2.3 CALIBRATION

Units are calibrated and checked for proper performance at the factory before they are shipped. However, unless calibration was requested to a specific set of input-output values, the unit should be calibrated by the user before the unit is placed in service.

### NOTE

Adjustments should *not* be made in the field on units that are calibrated to values specified in the purchase order. Units that are calibrated at the factory to customer's specifications have protective caps over the SPAN, INPUT ZERO, and ZERO potentiometers; DO NOT remove these caps.

An adjustable input signal source and input and output monitoring devices are required for calibration. The monitoring devices (current or voltage) must have an accuracy within  $\pm 0.05\%$  or better.

### NOTE

Refer to paragraph 1.6 for information on how to use the model number to obtain the specified values of minimum and maximum inputs and outputs.

To calibrate a unit, proceed as follows:

- a. Connect unit and test equipment as shown in Figure 2-1.
- b. Apply power input to the unit.
- c. Refer to Table 2-1 and adjust the input signal source to the value given in the INPUT column under the INPUT ZERO ADJUSTMENT heading and in the row with the INPUT RANGE corresponding to that of the unit.
- d. Adjust the INPUT ZERO potentiometer so the output is the value given in the REQ'D OUTPUT column immediately to the right of the INPUT value used in step (c).
- e. Adjust the input signal source to the value given in the INPUT column under the ZERO ADJUSTMENT heading and in the row with the INPUT RANGE corresponding to that of the unit.
- f. Adjust the ZERO potentiometer so the output is the value given in the REQ'D OUTPUT column immediately to the right of the INPUT value used in step (e).
- g. Adjust the input signal source to the value given in the INPUT column under the SPAN ADJUSTMENT heading and in the row with the INPUT RANGE corresponding to that of the unit.



- h. Adjust the SPAN potentiometer so the output is the value given in the REQ'D OUTPUT column immediately to the right of the INPUT value used in step (g).
- i. Repeat steps (c) through (h) as required until no further adjustment of the INPUT ZERO, ZERO, or SPAN potentiometers is necessary.
- j. Successively apply the inputs given in the applicable positions in the 50% INPUT and 75% INPUT columns under the OUTPUT CHECKS heading, and check that the corresponding outputs are the values given in the REQ'D OUTPUT columns immediately to the right of the respective INPUT columns (within  $\pm 0.25\%$  of the output span).
- k. After step (j) has been successfully completed, remove the input signal source and then turn off the power input to the unit.

## 2.4 MECHANICAL INSTALLATION

As mentioned in Section 1, the unit may be obtained in various physical configurations and/or case sizes. Figure 2-2 shows the outline dimensions and other installation requirements for the particular configuration supplied.

Be sure to observe the applicable special procedures and precautions given with the illustration. Although the units are designed to operate in free air at quite a high ambient temperature, it is advisable if possible to mount the unit on a surface made of material that can serve as a heat sink.

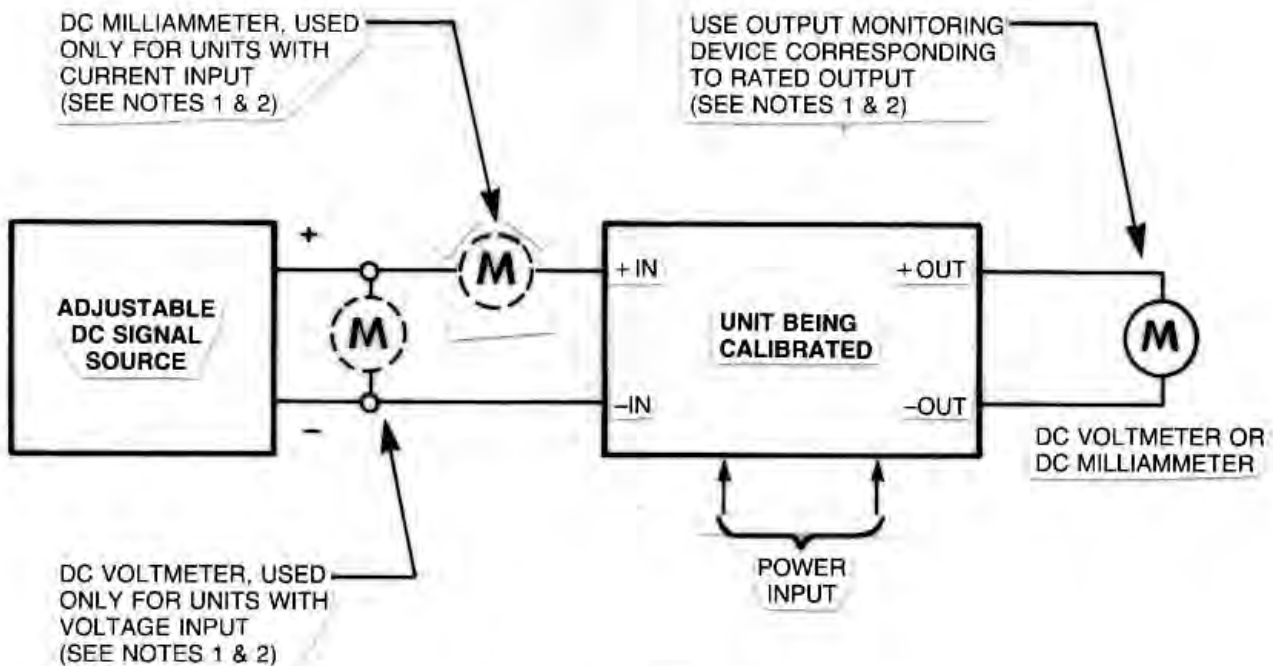

Figure 2-1

### NOTES:

1. INPUT AND OUTPUT MONITORING DEVICES MUST BE ACCURATE TO WITHIN  $\pm 0.05\%$
2. M.I.I. TEST SET PTS-770 MAY BE USED FOR CALIBRATION.

**TABLE 2-1. INPUT AND OUTPUT VALUES FOR INPUT ZERO, ZERO, AND SPAN ADJUSTMENTS, AND OUTPUT CHECK**

INPUT RANGE	OUTPUT RANGE	INPUT ZERO ADJUSTMENT		ZERO ADJUSTMENT		SPAN ADJUSTMENT		OUTPUT CHECKS			
		INPUT	REQ'D OUTPUT	INPUT	REQ'D OUTPUT	INPUT	REQ'D OUTPUT	50% INPUT	REQ'D OUTPUT	75% INPUT	REQ'D OUTPUT
1-5 mA	1-5 mA	1.04	1.4	2	3	5	5	3	3.828	4	4.464
	4-20 mA		5.6		12		20		15.312		17.856
	10-50 mA		14		30		50		38.28		44.64
	1-5 V		1.4		3		5		3.828		4.464
4-20 mA	1-5 mA	4.16	1.4	8	3	20	5	12	3.828	16	4.464
	4-20 mA		5.6		12		20		15.312		17.856
	10-50 mA		14		30		50		38.38		44.64
	1-5 V		1.4		3		5		3.828		4.464
10-50 mA	1-5 mA	10.4	1.4	20	3	50	5	30	3.828	40	4.464
	4-20 mA		5.6		12		20		15.312		17.856
	10-50 mA		14		30		50		38.28		44.64
	1-5 mA		1.4		3		5		3.828		4.464
0-2 V	1-5 mA	0.02	1.4	0.5	3	2	5	1	3.828	1.5	4.464
	4-20 mA		5.6		12		20		15.312		17.856
	10-50 mA		14		30		50		38.28		44.64
	1-5 V		1.4		3		5		3.828		4.464
0.5-2.5 V	1-5 mA	0.52	1.4	1	3	2.5	5	1.5	3.828	2	4.464
	4-20 mA		5.6		12		20		15.312		17.856
	10-50 mA		14		30		50		38.828		44.64
	1-5 V		1.4		3		5		3.828		4.464
0-5 V	1-5 mA	0.05	1.4	1.25	3	5	5	2.5	3.828	3.75	4.464
	4-20 mA		5.6		12		20		15.312		17.856
	10-50 mA		14		30		50		38.28		44.64
	1-5 V		1.4		3		5		3.828		4.464
1-5 V	1-5 mA	1.04	1.4	2	3	5	5	3	3.828	4	4.464
	4-20 mA		5.6		12		20		15.312		17.856
	10-50 mA		14		30		50		38.28		44.64
	1-5 V		1.4		3		5		3.828		4.464

NOTE: TO THE NUMBERS IN THE THIRD AND FOLLOWING COLUMNS, APPLY UNITS (MA OR V) IDENTICAL TO THOSE IN THE CORRESPONDING ROWS OF THE FIRST TWO COLUMNS, AS APPROPRIATE.

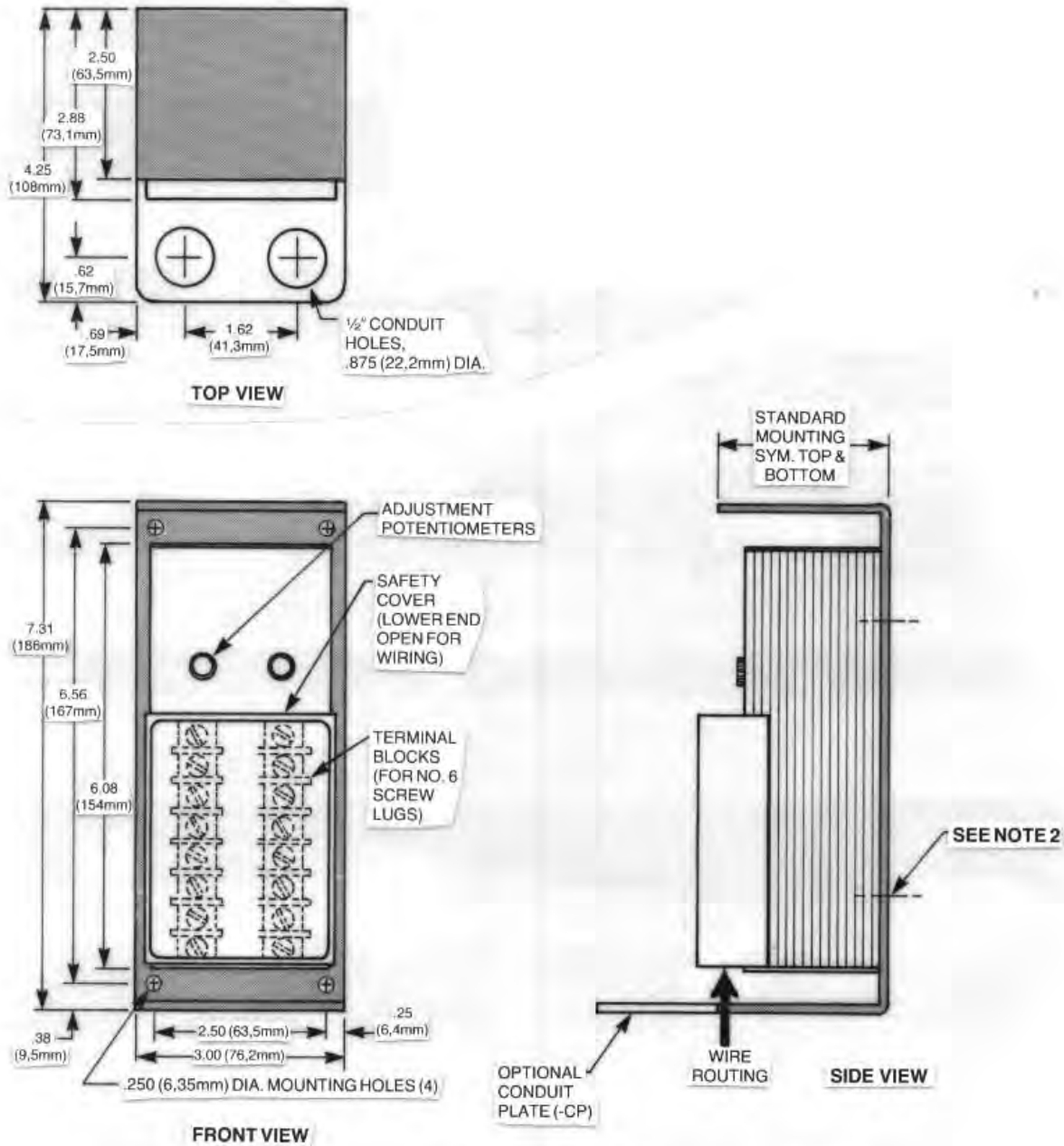

**Figure 2-2**

**Notes:**

1. Complete Model No. and Serial No. are permanently marked on the identification plate located at the upper end of the terminal blocks.
2. When extra-compact mounting is required for rack or portable installation, the C-shaped mounting bracket may be removed and the two threaded inserts (located 4.00 inches apart) may be used for mounting, using 6-32 NC machine screws.

**CAUTION:**

WHEN THE REAR INSERTS ARE USED FOR MOUNTING, BE SURE THAT THE MOUNTING SCREWS DO NOT PROTRUDE MORE THAN 1/8 INCH INTO THE UNIT.



## 2.5 ELECTRICAL CONNECTIONS

All electrical connections are made to the terminal blocks in the unit. The terminals to be used for the electrical connections are indicated in Figure 2-3. The following paragraphs provide additional information on wiring the unit.

### 2.5.1 General Wiring Techniques

No special wire or cable is required for signal connections to the unit. To avoid transients and stray pickup, it is recommended that twisted conductors be used where they are run close to other services (such as power wiring). On open units supplied with a snap-off cover, dress all wiring up through the opening in the bottom of the cover. Spade-lug connectors are recommended for all wire terminals. All terminals are supplied with 6-32 screws long enough to easily accept three spade-lug connectors.

### 2.5.2 Power Connections

A given unit is designed to be operated from either a DC power source or an AC power source. Refer to paragraph 1.6 for information on how to use the model number to determine the type of power required.

On DC-powered units, the DC terminal is connected to the + (positive) side of the source, and the DCC terminal is connected to the – (negative) side. The DC source should be regulated to within 10% of the nominal voltage and should be capable of delivering 5 watts.

On AC-powered units, 117 volts AC 10%, 50/60 Hz, 5 VA nominal power is required. The AC terminal should be connected to the ungrounded or "hot" side of the supply, if possible, and the ACC terminal is connected to the common or neutral side. The GND terminal is the mechanical case connection.

### 2.5.3 Connections On Units With SC Option

On units with the SC (selectable current) option, connect the input selectable current resistor to the + IN and –IN terminals. Connect the output selectable current resistor to the terminals marked SC. The current range is marked on the body of each resistor.

### 2.5.4 Connections On Units With TX Option

On units with the TX Option, connect the positive lead of the external sensing unit to + TX terminal, and the negative lead of the external sensing unit to + IN terminal.

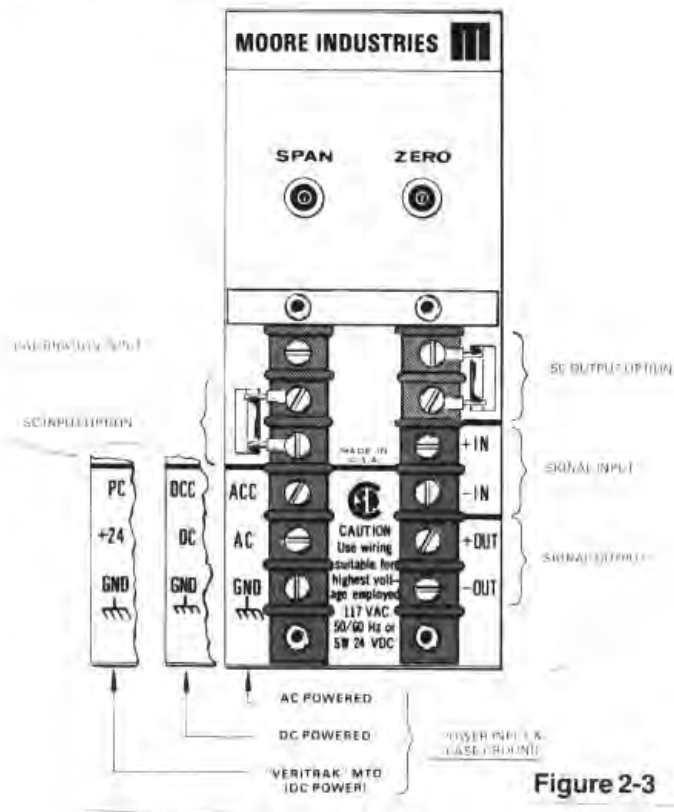

Figure 2-3 Electrical Connections For Unit

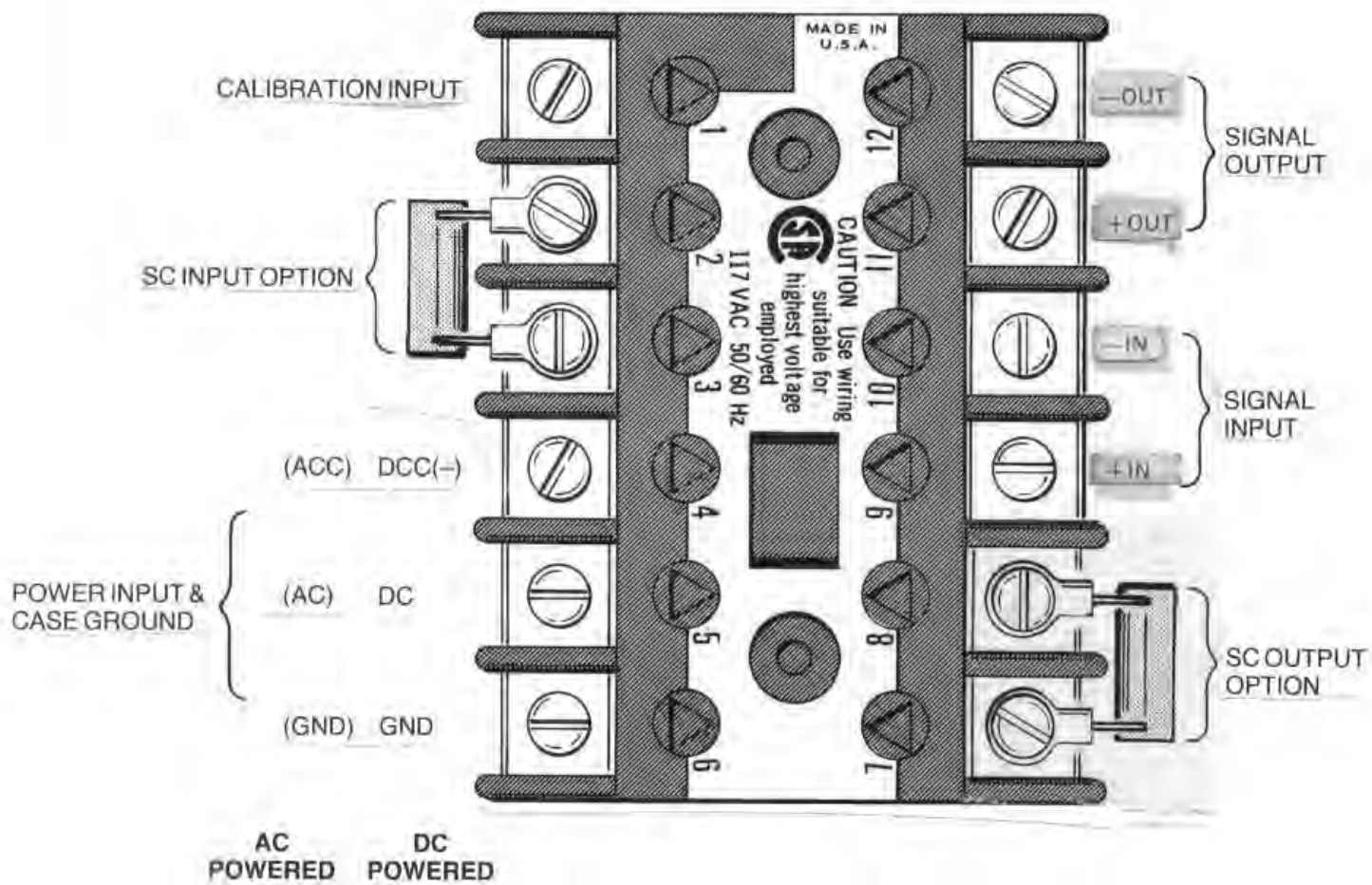

Figure 2-3 Electrical Connections For -EX (Explosion Proof) Housing Mounted Single Unit & -PST Std. Plug-In Units

### **3.1 OPERATING PROCEDURE**

Once calibrated and installed, the unit may be operated unattended. The only controls on the outside of the unit are the SPAN, ZERO, and INPUT ZERO potentiometers which, after initial adjustment, need no further attention. There are no indicators on the unit. Because the circuit uses highly reliable solid-state components with no moving parts, the unit should operate virtually maintenance-free for a long period of time. However, if a malfunction should occur, refer to Section 5 for maintenance information.

A unit may become warm during operation, especially where the ambient temperature is rather high. This is perfectly normal and should not be a cause for alarm unless a malfunction is also observed.

## 4.1 INTRODUCTION

This section describes the theory of operation of the unit. The description is made at two levels. First, a block-diagram description of each function of the unit is presented to provide information on the overall operation of the unit. The circuits are then described in more detail to provide maintenance personnel with a thorough understanding of how each circuit operates so malfunctions can be located and corrected as rapidly as possible.

## 4.2 FUNCTIONAL DESCRIPTION

Figure 4-1 is a functional diagram of the unit, with both the AC-operated power supply and the DC-operated power inverter indicated. It should be noted, however, that a given unit will have either the power supply or the inverter, but not both. In the following functional description, which is based on Figure 4-1, simply disregard those elements of Figure 4-1 and the corresponding text that do not apply.

### 4.2.1 Functional Description Of AC Power Supply

When AC power input is applied, the power supply produces AC voltages of three different amplitudes (with respect to ground). These are applied to the rectifier and regulator, which develop regulated and unregulated DC outputs that are used as operating voltages for the unit.

### 4.2.2 Functional Description Of Power Inverter

The power inverter accepts DC power input and produces three square-wave outputs. These square-wave outputs, instead of outputs from the AC power supply, are then applied to the rectifier and regulator, which function in the usual manner. A diode in the DC (positive) lead will prevent damage to components in the power inverter if the DC power source is accidentally connected with incorrect polarity.

### 4.2.3 Functional Description of Rectifiers and Voltage Regulators

The main rectifier accepts the output from either the AC power supply or the power inverter and produces unregulated positive and negative voltages (of equal value with respect to ground). Two regulators reduce these voltages to the required operating values and regulate them against changes with load or line voltage variations. Another rectifier produces a higher unregulated output that is used as operating voltage for the power amplifier.

### 4.2.4 Functional Description Of Ramp Generator

The ramp generator produces an output that periodically

increases at a constant rate to a specific maximum positive value and then decreases at the same rate to zero. Operation of the ramp generator is at a constant frequency. The output of the generator is applied to one side of a comparator that produces the basic drive signal for the switches that control the output from the input amplifier.

The main elements of the ramp generator are a ramp comparator and integrator. This circuit also includes a switch and plus and minus clamps. One side of the ramp comparator is fed with a fixed positive voltage derived from the +V1 voltage. Assume that the output of the ramp comparator is initially saturated negative. This output is applied to the switch, keeping it turned off, and also to the integrator (clamped at -6.2V), causing it to produce an increasing output. The rising integrator output is applied to the other side of the ramp comparator. When the rising integrator output just equals the fixed positive voltage applied to the opposite side of the ramp comparator input, the comparator output rapidly switches to positive saturation, thus turning on the switch and removing the fixed positive voltage as one input to the comparator. This same positive output from the ramp comparator, clamped at +6.2V, also drives the integrator and thereby drives its output toward zero.

With the switch turned on, the ramp comparator is driven only by the decreasing output of the integrator. When the integrator output becomes zero, the output of the ramp generator rapidly changes to negative saturation, turning off the switch and again allowing the fixed positive voltage applied to one side of the ramp comparator to control the ramp generator. Thus, a new ramp cycle is initiated. The ramp comparator and integrator operate from the +V1 and -V1 voltages.

### 4.2.5 Functional Description Of Switch Drive Circuit

The switch drive circuit consists of a comparator and inverting amplifier. One side of the comparator is driven by the output of input amplifier No. 2, and the other side is driven by the output from the integrator in the ramp generator. As long as the drive from the ramp generator is less than that from input amplifier No. 2, the comparator produces a negative output that turns off the shunt switch and inverting amplifier. The output at the inverting amplifier turns on the series switch. When the output of the ramp generator becomes slightly greater than that of input amplifier No. 2, the comparator produces a positive output that turns on the shunt switch and the inverting amplifier, thus turning off the series switch. The switches remain in these states until the ramp output again falls below the output of input amplifier No. 2, at which time the series switch is again turned on and the shunt switch turned off. The process then repeats. The comparator operates from the +V1 and -V1 voltages, and the inverting amplifier operates from the +V1 voltage.

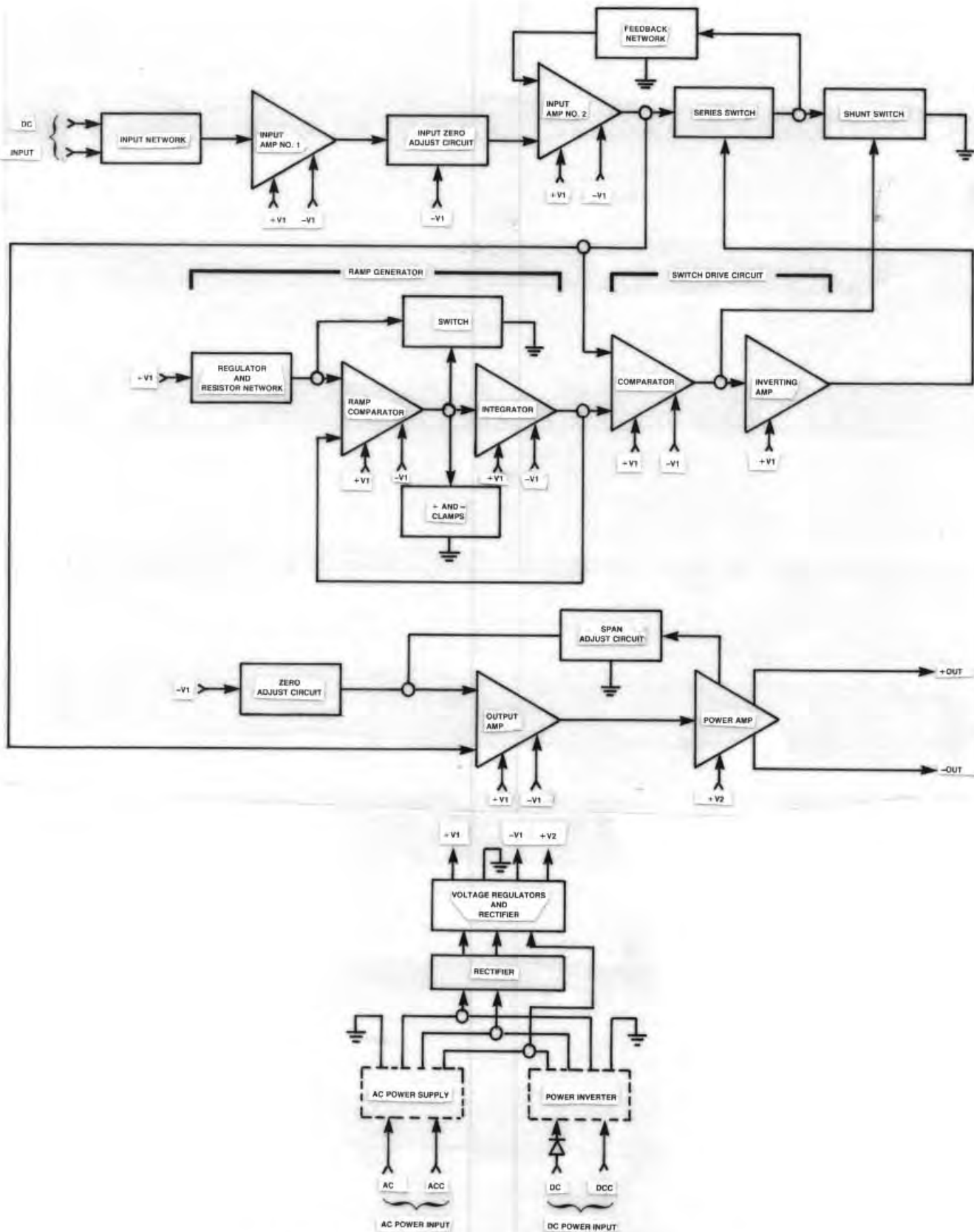

Figure 4-1 Functional Diagram Of Transmitter



#### 4.2.6 Functional Description Of Input Network And Input Amplifier No. 1

The input network provides the input signal with the proper termination. The signal is then applied to input amplifier No. 1. Feedback is used to establish the amplifier gain and also to achieve high stability of amplifier operation. The input zero adjust circuit, which operates from  $-V_1$ , adds an adjustable negative voltage to input amplifier No. 2. This voltage modifies the live zero (if present) of the signal from input amplifier No. 1 so the span of the signal applied to input amplifier No. 2 corresponds to that of the physical quantity represented by the input signal applied to the unit. Input amplifier No. 1 operates from the  $+V_1$  and  $-V_1$  voltages.

#### 4.2.7 Functional Description Of Input Amplifier No. 2 And Switches

Input amplifier No. 2 is an operational amplifier with feedback arranged so the amplifier produces an output proportional to the square root of the applied input. The amplifier is driven by input amplifier No. 1, which supplies a signal proportional to the signal applied to the input of the unit with the live zero modified by the input zero adjust circuit. With the response of input amplifier No. 2 intentionally slowed by an external network, the output of the amplifier is a nearly pure DC signal. This output signal is chopped by the series and shunt switches into a rectangular wave with an instantaneous value that is either positive or zero. In general, the durations of these values are not equal. Thus modified by the switches, the output of the amplifier is applied to the input of the feedback network. A low-pass filter makes the feedback signal actually applied to the amplifier proportional to the DC average of the rectangular wave. The switches are arranged so the unchopped (DC) output of the amplifier is available to drive the following amplifier.

Several interrelated factors combine to establish the DC average level present at the junction of the switches. First, this DC average level is proportional to the time during which the series switch is on, relative to the time for one ramp cycle. Because the DC average output of input amplifier No. 2 drives one side of the comparator, the time during which the series switch is on is proportional to the output from this amplifier. In addition, the DC average output of the amplifier determines the amplitude of the positive portion of the rectangular wave produced by the switches. Thus, it is seen that the DC average of the chopped output of the amplifier is proportional to the *square* of the DC average (unchopped) output of the amplifier, and this *squared* output is proportional to the span of the applied input signal. Since it is

the DC average output (not the *squared* output) that is of interest, it is evident that this output is proportional to the square root of the span of the signal applied to the unit. Input amplifier No. 2 operates from the  $+V_1$  and  $-V_1$  voltages.

#### 4.2.8 Functional Description Of Output Amplifier

The amplifier accepts the DC average output from input amplifier No. 2 and increases the level of the signal so it can drive the output amplifier. A low-pass filter in the amplifier removes any high-frequency components present in the signal from input amplifier No. 2 as a result of the action of the switches. The zero adjust circuit, which is derived from  $+V_1$  and  $-V_1$ , applies an adjustable positive and negative voltage to the amplifier input that is not driven by input amplifier No. 2. This voltage causes the amplifier to produce an output that results in the desired output from the unit with a 0% input signal applied. Feedback, adjustable through the span adjust circuit, is also applied to this same input of the amplifier and controls the amplifier gain so the unit produces the desired maximum output with 100% input signal applied. The amplifier operates from the  $+V_1$  and  $-V_1$  voltages.

#### 4.2.9 Functional Description Of Power Amplifier

The power amplifier increases the power level from the amplifier to produce an output signal that will drive the load in the required manner. For all the current ranges, the amplifier uses two transistor stages to develop the required output. A single transistor is used for voltage output. The power amplifier operates from the  $+V_2$  voltage.

### 4.3 CIRCUIT DESCRIPTION

The following paragraphs describe the operation of the various circuits in sufficient detail so troubleshooting, if required, can be carried out intelligently and rapidly. Except where otherwise indicated, refer to the SRT schematic diagram near the end of this manual when reading these paragraphs.

#### 4.3.1 Description Of AC Power Supply Circuit

The AC power supply circuit consists basically of a power transformer that produces three different AC outputs with respect to common. Referring to the SRT schematic diagram, VS1 is connected across the primary of the power transformer T1 and suppresses transients that may be present on the power line. Each half of the center-tapped secondary of T1 develops 18 volts, and the other secondary produces 36 volts. The



voltage from the center-tapped secondary is applied to CR6, and that from the other secondary is applied to a half-wave rectifier.

#### 4.3.2 Description Of Power-Inverter Circuit

Drawing 400-404-00 is the schematic diagram of the power inverter (PCA) used on the standard units. When the unit is ordered for use with DC power, the power inverter is used instead of the AC source (T1) shown on the SRT schematic diagram. The DC applied to the power inverter is converted to a square wave of approximately 3 KHz by Q1, Q2, and the primaries of T1 (PCA schematic diagram), functioning as a DC-to-AC inverter. Filter L1-C1 on PCA prevents the 3-KHz signal from getting back into the external DC source. CR1 provides protection against damage from inadvertent application of DC of incorrect polarity. The square-wave output from center-tapped secondary 8-13 is applied to CR7, CR8, and that from secondary 17-16 is applied to PC2 (paragraph 4.3.3).

#### 4.3.3 Description of Rectifier And Regulator Circuit

Diode CR6 consists of two sets of full-wave rectifiers arranged to produce both positive and negative DC outputs (with respect to the grounded center tap of the transformer winding that feeds the rectifier). The positive and negative DC outputs from CR6 are applied to pins 6 and 5 of power supply regulator PC2 (drawing 152-402-00). PC2 consists of two filters and voltage regulators (one each for the positive and negative outputs from CR6) and a half-wave rectifier and filter. The unfiltered positive output from CR6 is filtered by C203 and then regulated to +12 volts output by pass transistor Q202, the base of which is clamped at 12 volts by CR204. Similar action to produce -12 volts output is accomplished by C202, Q201, and CR203. Half-wave rectifier CR202 and filter C201 produce a higher unregulated positive voltage (approximately +38 volts) from the transformer winding that is not center-tapped. This higher voltage is used by the power amplifier.

#### 4.3.4 Description Of Ramp Generator Circuit

In the ramp generator, IC3 and associated components form the ramp comparator, Q2 serves as the switch, and IC1 and its associated components act as the integrator. CR4, fed from the +12-volt source through R18, produces a regulated voltage of +6.2 volts, which is applied to pin 2 (the inverting input) of IC3. If the signal applied to pin 3 of IC3 from the output of IC1 is assumed, for the moment, to be zero, IC3 will be driven only by the positive signal applied to pin 2 and thus produce a negative output signal at pin 6. This negative output is applied through R1 to the base of Q2 and turns off this switch. CR1 limits the negative voltage that can be applied to the base of Q2 to approximately 0.6 volt. The output from IC3 is also applied through R3 to CR2 and clamped at this point to -6.2 volts. The clamped signal is applied through R4 to pin 2 (the inverting input) of IC1.

Under the influence of this signal and the action of C1, IC1 produces an output that begins to rise at a constant rate, and this output is applied through R17 to pin 3 (the non-inverting input) of IC3. When the rising signal at pin 3 of IC3 becomes greater than the positive voltage applied to pin 2, the output of IC3 rapidly changes to positive saturation. This positive output of IC3 turns on Q2, which short circuits pin 2 of IC3 to ground and thus removes the effect that the fixed positive voltage had in controlling the action of the ramp comparator. Now feedback from the integrator output to pin 3 of IC3 regeneratively locks IC3 to keep its output positive (under the conditions just described). The positive output of IC3 is clamped to +6.2 volts by CR3, and the resulting positive signal is applied to pin 2 of IC1. Since the signal applied to the inverting input of IC3 is now positive, the output of IC1 begins to decrease toward zero at the same rate it originally increased from zero to its maximum positive value. Because pin 2 of IC3 is grounded by Q2 (which is now turned on), the output of IC3 will remain positive until the ramp output from IC1 reaches zero. When this occurs, the output of IC3 again reverses polarity and becomes negative, turning off Q2 and starting a new ramp cycle. Both IC3 and IC1 operate from +12 volts and -12 volts.

#### 4.3.5 Description Of Switch Drive Circuit

Switch drive circuit consists of comparator IC6 and inverter Q1. The ramp output from IC1 is applied through R20 to pin 3 (the non-inverting input) of IC6, and the output from input amplifier No. 2, IC4 is applied through R34 to pin 2 (the inverting input). When the ramp signal is just beginning its rise from zero, it is lower in amplitude than the signal from IC4, which is proportional to the span of the input signal applied to the unit. Under this condition, IC6 produces a negative output that is applied through R21 to turn off Q3, and is also applied through R2 to turn off Q1. With Q1 off, the positive voltage at its collector is applied through R22 to Q4, turning on this switch. Q4 and Q3 remain in their respective on and off states until the ramp output from IC1 rises above the output from IC4 and causes IC6 to reverse and the polarity of its output. At this point, Q4 and Q3 reverse their states and remain in their new states until the ramp output again becomes less than the signal applied to pin 2 of IC6. IC6 operates from +12 volts and -12 volts, and Q1 operates from +12 volts.

#### 4.3.6 Description Of Input Network And Input Amplifier No. 1 Circuit

R5 provides a current input signal with the proper termination. The signal is applied through R6 to pin 3 (the non-inverting input) of IC2, which serves as input amplifier No. 1. Feedback from the output at pin 6 is applied through R7 to pin 2 (the inverting input) of IC2. The output of IC2 is applied through R9 to pin 3 (the non-inverting input) of input amplifier No. 2, IC4. An adjustable negative voltage obtained from the input zero adjust circuit is also applied through R26 to this same input on IC4. The input zero adjust circuit consists of R37, the

INPUT ZERO potentiometer, and R35, connected across  $-6.2$  volts, which is regulated by CR10 and derived through R39 from  $-12$  volts. The INPUT ZERO potentiometer is adjusted so the voltage at its wiper, when combined through R26 with the output of IC2, causes IC4 to be driven so it produces the required output. Thus, the voltage at the wiper of the INPUT ZERO potentiometer modifies the live zero of the output from IC2 so the span of that signal corresponds to that of the physical quantity represented by the input signal applied to the unit. IC2 operates from  $+12$  volts and  $-12$  volts.

#### 4.3.7 $-TX$ or $-TXH$ Option, Circuit Descriptions

The  $-TX$  or  $-TXH$  option circuits, illustrated in Figure 4-2, consist of a 38 volt excitation signal supplied by the SRT to the external sensing unit. The  $-TXH$  option provides the excitation power across the  $+IN$  and  $-IN$  terminal. In this configuration, resistor R5 acts as an input voltage divider. The  $-TX$  option provides the excitation power from an additional terminal ( $+TX$ ) to develop the input signal across resistor R5.

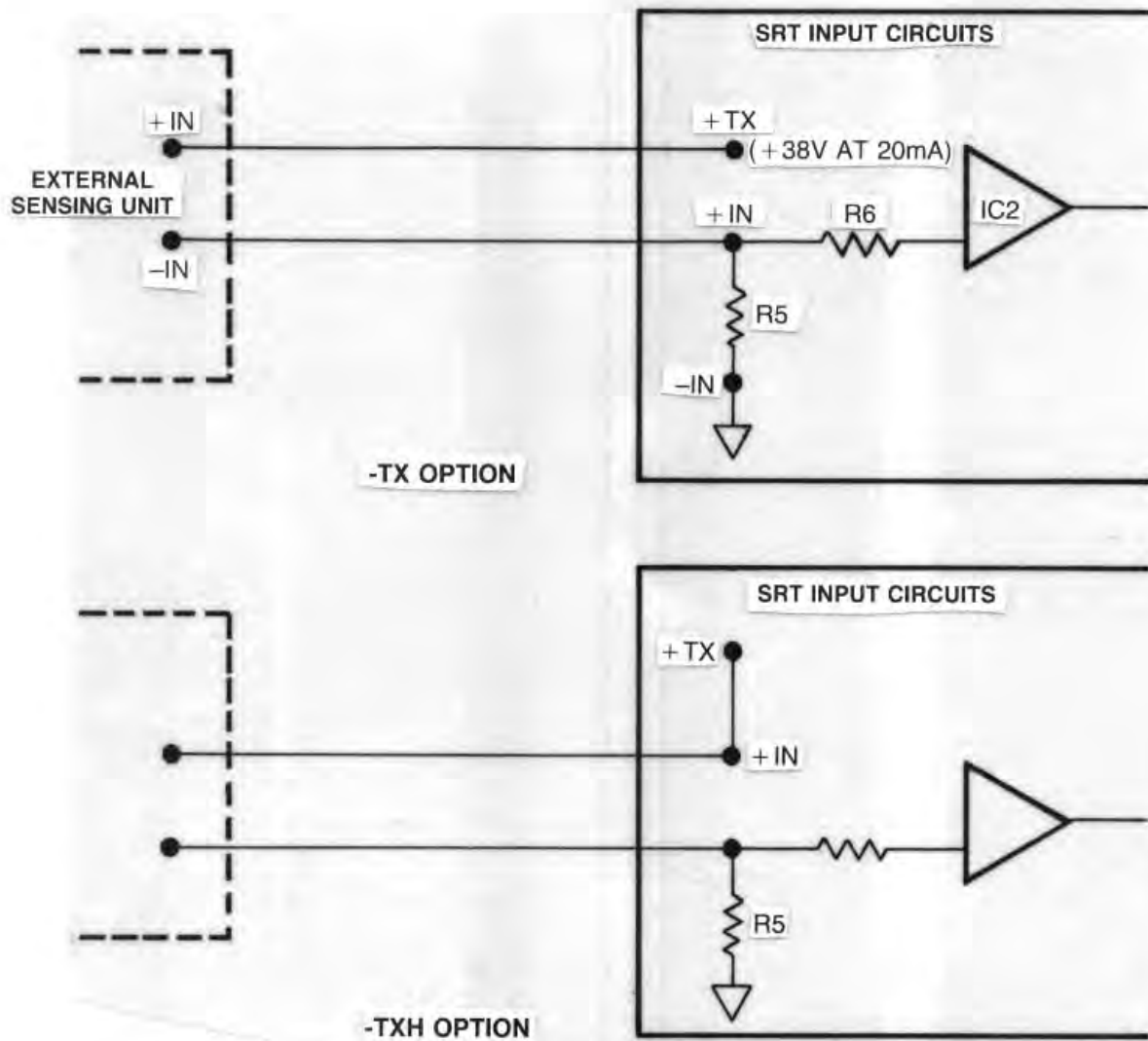

Figure 4-2  $-TX$  or  $-TXH$  Options Input Circuits Block Diagrams

#### 4.3.8 Description Of Input Amplifier No. 2 And Switch Circuit

IC4 is input amplifier No. 2, and Q4 and Q3 serve as the series and shunt switches, respectively. When Q4 is on and Q3 is off, the DC level at the junction of the emitter of Q4 and the collector of Q3 equals the output at pin 6 of IC4. R25 and C5 make the amplifier response relatively slow and therefore make the output at pin 6 a nearly pure DC signal. When Q4 is off and Q3 is on, the DC signal at this same junction of the switches is zero because Q3 acts as a short circuit to ground. As was previously explained, the DC average level developed at this point is proportional to both the output from IC4 and the fraction of a ramp cycle during which Q4 remains on, which itself is proportional to the output from IC4. This DC average level at the junction of the switches is fed back through R33 to pin 2 (the inverting input) of IC4. R33 and C7 form a low-pass filter that removes any high-frequency signal components resulting from switching action and leaves at pin 2 only the average level of the rectangular signal developed by Q4 and Q3. As was previously pointed out, the switches cause the feedback signal applied to pin 2 to be proportional to the square of the DC output at pin 6, which, in turn, is proportional to the signal applied to pin 3 (i.e., the span of the signal applied to the unit). Since the feedback signal in an operational amplifier tends to become equal to the external driving signal, IC4 is thus controlled so its output is proportional to the square root of the span of the input signal applied to the unit. IC4 operates from +12 volts and -12 volts.

#### 4.3.9 Description Of Output Amplifier Circuit

The output amplifier consists of IC5 and associated components. The output from IC4 is applied through R32 and R36 to pin 3 (the non-inverting input) of IC5 and to R11-C3 connected between this pin and ground. The three resistors form a voltage divider to reduce the signal to the proper level, and R32, C2, R10, R11, and C3 form a low-pass filter that removes any high-frequency (switching) components present in the signal. An adjustable negative voltage from the zero adjust circuit is applied through R13 to pin 3 of IC5 to establish the output from the unit with a specific signal near, but not equal to, a 0% signal. The zero adjust circuit consists of R28, R38 and the ZERO potentiometer, and operates from the same  $\pm 6.2$  volt source that supplies the input zero adjust circuit (paragraph 4.3.6). A portion of the output signal from the power amplifier is fed back through R14 and the SPAN potentiometer through R15 to pin 2 of IC5 to establish the gain of IC5 and therefore the output of the unit with 100% input signal applied, IC5 operates from +12 volts and -12 volts.

#### 4.3.10 Description Of Power Amplifier Circuit

The power amplifier consists of Q5, Q6 and Q7. It is a DC amplifier and can be arranged to provide either current or voltage output. For current output, the power amplifier is connected as a two-stage DC amplifier. The output is taken from the common connection of the two output driver collectors. These are connected essentially in parallel to provide current capacity. Feedback to pin 2 of IC5 is taken from the emitter of Q5 and Q6 through R41 and R42 respectively. In units with the SC option on the output, the optional selectable current output resistor R102 replaces R43. For voltage output, only IC5 is used as the output amplifier, with feedback taken from the junction of R40 and R31. The power amplifier operates from +38 volts for current output only.

## 5.1 INTRODUCTION

This section contains information on maintenance of the unit. General troubleshooting procedures are given, using conventional signal-tracing techniques. Precautions and special techniques used to replace components are also described.

## 5.2 PERIODIC MAINTENANCE

It is suggested that the calibration of the unit be checked approximately every 6 months as described in Section 2. No other periodic maintenance is required.

## 5.3 CORRECTIVE MAINTENANCE

The following paragraphs provide information on corrective maintenance of the unit. Corrective maintenance should be carried out *only by qualified personnel* who have read and thoroughly understand the description of circuit operation given in Section 4.

### 5.3.1 Disassembly

To troubleshoot the unit, it is first necessary to disassemble it so the circuit board is exposed. The physical configuration of the unit determines the steps to be followed in disassembly, and these steps are described in the following paragraphs. In all cases, disconnect the input signal and turn off the power input before disassembling the unit.

#### 5.3.1.1 Disassembly Of Standard And-CP Units

To disassemble a standard or -CP unit, remove the unit from its installed position. If the mounting bracket is used, separate it from the unit by removing the two countersunk screws at the rear of the unit. After the unit has been removed from its installed position, disassemble the unit as follows to gain access to the circuit board:

- a. Remove the two front Phillips-head screws at the top of the unit.
- b. Remove the four Phillips-head screws at the bottom of the unit.
- c. Slide the front panel (with the circuit board still attached) down and free of the sides of the case. Points on the circuit board may now be reached for troubleshooting. It is suggested that the case be used as a container for storing the removed hardware.

#### 5.3.1.2 Disassembly Of An Explosion-Proof Unit

To disassemble an explosion-proof enclosure (in addition to the case), proceed as follows:

- a. Use a bar wrench to loosen the housing cover from the base, and then unscrew and remove the housing cover to expose the unit.
- b. If required, remove the unit from the socket by rocking the unit slightly while pulling upward until it is free of the socket. The socket and terminal card are keyed to eliminate error when the unit is reinstalled.

### 5.3.2 Troubleshooting

The schematic diagrams include flagged numbers (or letters) at various points in the circuit. Table 5-1 gives the voltages and waveforms at these points for specified input-signal conditions. The assembly drawings show the physical location of the parts on the circuit board. Bear in mind that the circuit board is protected with a moisture-resistant coating. Therefore, it may be necessary to use a needle-point probe and exert a fair amount of pressure to break through the coating when it is desired to observe the signal or voltage at a specific point. When connecting a probe to a component on the circuit board, exercise care to make sure the probe does not short-circuit to an adjacent component. In general, troubleshooting is carried out by tracing the signal with an oscilloscope and referring to the schematic diagrams to determine what component might be causing an observed abnormal indication. If the original symptom was a complete failure of the unit to operate, the most logical components to suspect are those associated with the power supply in the unit (including any voltage regulators). If the unit was producing an incorrect (but not zero) output, check the outputs from the voltage regulator board and, if these are normal, apply a standard input signal and trace the resulting signal through the unit.

### 5.3.3 Component Replacement Techniques And General Precautions

Replace all defective components with identical parts. Refer to Section 6 for a list of replacement parts. A number appears in the extreme right margin after the description of certain parts in this list. The number indicates the number of spares recommended to be kept on hand for that part, per unit, for up to ten units of the same type. For more than ten units, a spares complement of 10% on the indicated parts should be used.



Most parts used in the unit are quite small and are located in a confined area. Therefore, small hand tools are a necessity when servicing the unit. The following is a summary of the general techniques and precautions that should be observed to prevent damage to components in the unit:

- Use a transformer-operated low-voltage soldering iron with a grounded tip and rated at not more than 50 watts. A temperature-controlled tip is desirable.
- Use extreme care when unsoldering the leads to any component. Do not keep the soldering iron on a point for more than a few seconds at a time. Use a suction-type solder-removing tool (solder sucker) as an aid in unsoldering transistors and integrated circuits. The protective coating on the unit may be removed with trichloethane or equivalent. Be sure adequate ventilation is provided when using this or any other chemical.

**NOTE**

Unused connections on integrated circuits are left unsoldered to aid in removal. Refer to the assembly drawing for more complete information.

- Do not excessively bend or twist the leads of small components; they break easily.
- Before removing a component, observe the lead dress. Be sure that the lead dress of the replacement is the same as that of the original.

- Remove all flux from soldered joints with trichlorethane or equivalent.

**NOTE**

Units that were calibrated at the factory to customer's specifications have protective caps over the SPAN, INPUT ZERO, and ZERO potentiometers. These caps must be removed so the unit can be recalibrated. LIFT, DO NOT TWIST, the caps off, using a screwdriver tip as a prying tool. Snap the caps back in place, WITHOUT TWISTING, when recalibration has been completed.

- Test the unit for proper operation and, if necessary, recalibrate by the procedure given in Section 2. When the performance of the unit is known to be satisfactory, apply clear acrylic to reseal the unit where required.
- Check that all leads are clear of the board edge before reinstalling the board into its case.
- When reinstalling the unit onto the mounting bracket, be sure to use the same screws (or screws of the same size) as the ones removed. Longer screws will damage the unit.

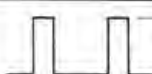
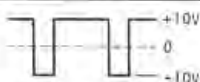
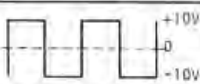
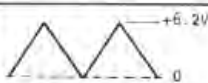
TEST POINT(S)	WAVE FORM AND AMPLITUDE OR VOLTAGE LEVEL
1	 0-2.5 v
2	AMPLITUDE PROPORTIONAL TO THE SQUARE ROOT OF WAVE FORM 1
3	 AMPLITUDE PROPORTIONAL TO THE SQUARE ROOT OF WAVE FORM 1
4	 +10v 0 -10v
5	 +10v 0 -10v
6	 +6.2v 0

**TABLE 5-1  
WAVEFORMS AND  
VOLTAGES**

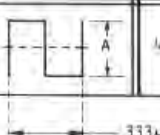
TEST POINT	WAVE FORM	POWER INPUT AND WAVE FORM AMPLITUDE				
		24 VDC	45 VDC	65 VDC	117 VAC	220 VAC
4	 A 333µs	48v	90v	130v	48v	48v

## 6.1 GENERAL

This section consists of a computer print-out table that provides parts identification information for the unit. Wiring lists have been provided in this section as an aid to the maintenance personnel.

Parts information is grouped according to the number of assemblies. If the unit contains two PC boards, the table will be divided into two major sections: one section will contain information related to PC1 and the other section will list PC2 components information. Each major section in the table contains a complete parts list headed LIST OF MATERIALS specifying which PC board it is describing. This list of materials consists of the following headings:

*ITEM:* A reference numeral used for data processing and not used by maintenance personnel.

*NAME:* Gives the nomenclature of the part.

*DESCRIPTION:* Identifies the component by manufacturer's part number, usually followed by component's parameters or value.

*REF:* Lists the reference designation for the component, referred to in Section 4, on the schematic and assembly drawings.

*PART NUMBER:* This column specifies the Moore Industries assigned part number. This is the part identification required when ordering parts from Moore Industries.

*SPARE:* The numeral in this column specifies the recommended number of component spares per unit type that should be kept on hand by maintenance personnel.

## 6.2 GLOSSARY OF ABBREVIATIONS

C	Capacitor
CR	Diode - zener included
HW	Special hardware
J	Connecting buss wire
L	Inductor
LB	Label
PC	Printed circuit board
R	Resistor
T	Transformer
IC	Integrated circuit
Q	Transistor
LED	Light emitting diode
TB	Terminal block
VS	Voltage regulating varistor
VR	Voltage regulator



152-401-00  
STD SRT SCHEM

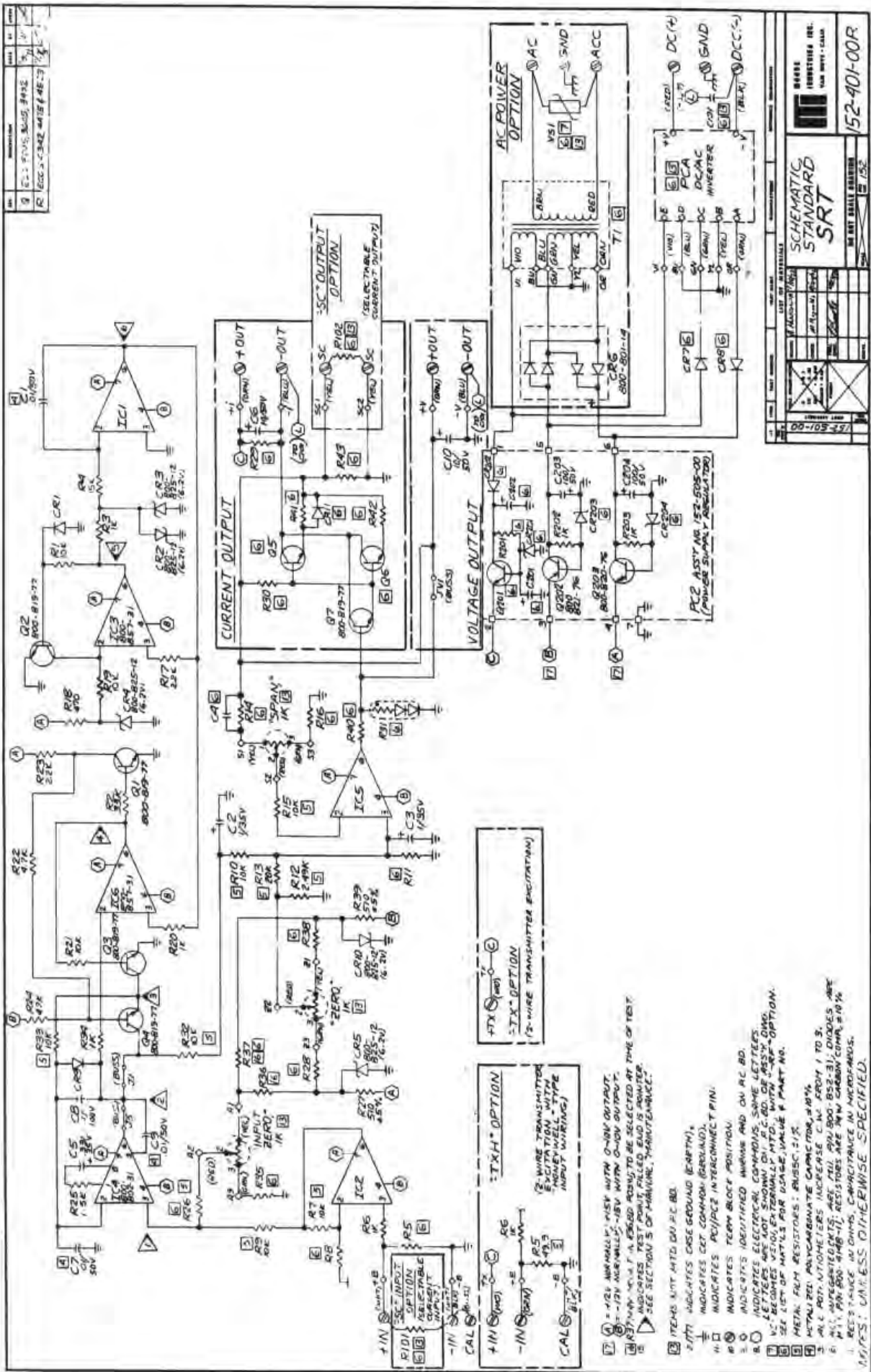

SCHEMATIC STANDARD SRT

152-401-00R

BOOKS

RESISTING INC.

152

4. ALL LEADS TO BE SOLDERED TO PADS.
5. SEE PAGE 2 FOR ADDITIONAL COMPONENTS.
1. CATHODE END OF CR1 & CR4 FACES DOWN.
2. INSTALL HW'S WITH "LOCKTITE" ON THREDS.
3. SLEEVE INDICATES METAL SIDE OF QS FWD.
1. ALL JUMPER ARE 22AWG BUSS TETLON UNLESS OTHERWISE SPECIFIED

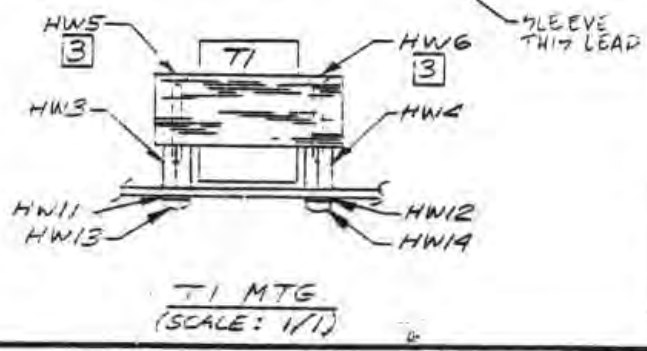
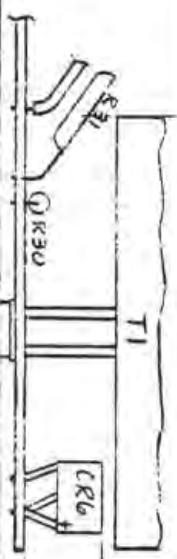
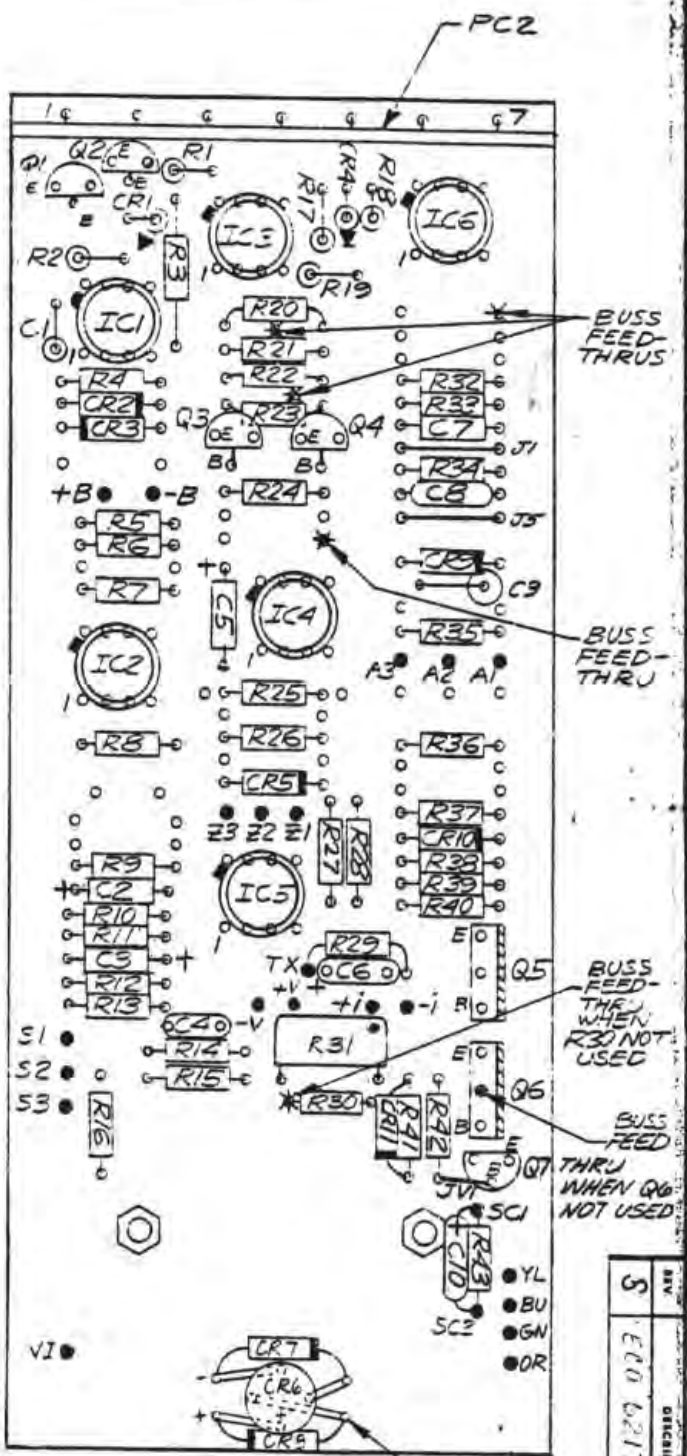

NO. OF PAGES		1	
DASH NO.		NEXT ASSEMBLY	
FINISH		MATERIALS	
CHECK		DRAWING	
MATERIALS		MANUFACTURER	
DO NOT SCALE DRAWING		P.C. BOARD ASSY STANDARD SRT	
DATE 2/1/NOTED		JOB NO 152	
152-501-005		MOORE INDUSTRIES INC. VAN NUYS, CALIF.	

REV	DESCRIPTION	DATE	BY	APPV
5	ECO 6217			

(SEE PAGE 1)

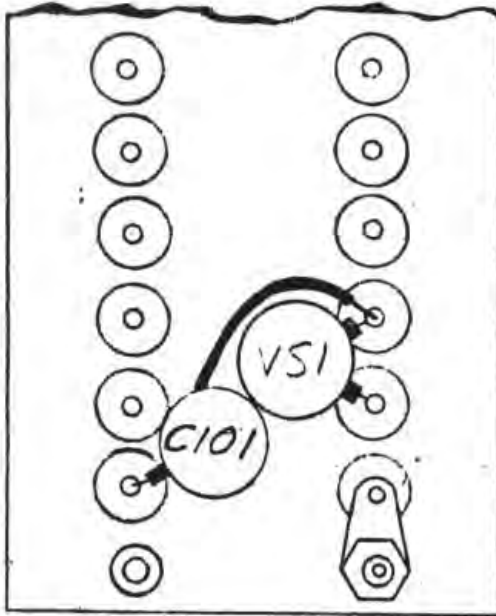

VSI, C101  
(SLEEVE LEADS)

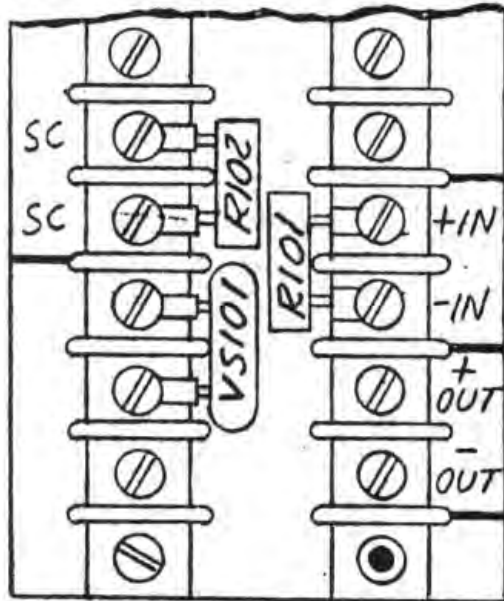

R101, R102, VS101

"SR & CH"

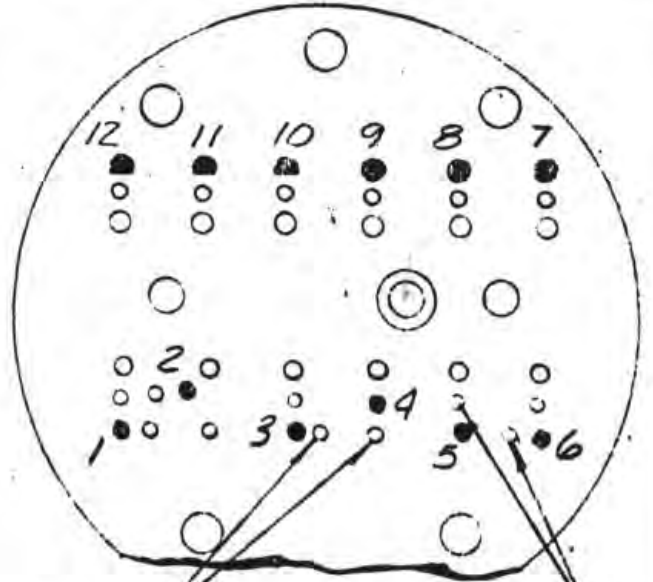

MTG HOLES FOR C101

MTG HOLES FOR VSI

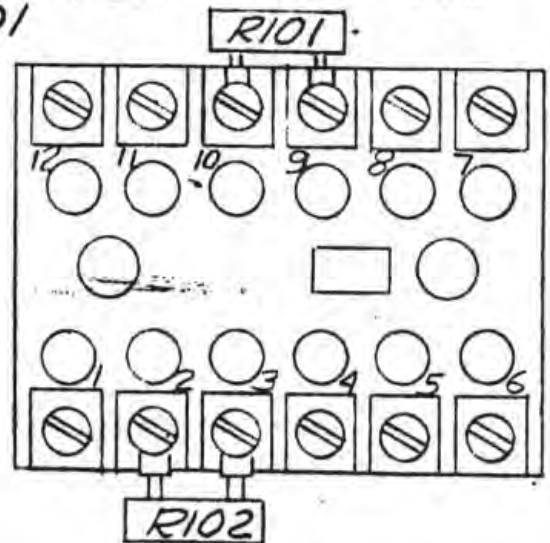

"SP"

DIMENSIONS ARE IN INCHES UNLESS NOTED OTHERWISE

TOLS. UNLESS NOTED:  
 .X = ±.10  
 .XX = ±.030  
 .XXX = ±.010  
 ANGLES = ± 30°

DO NOT SCALE DRAWING

SCALE: 1/1

DRAWN	C. FIEDERER	5/10/74
CHECKED	R. Kelley	10/23/74
PROJ. ENGR.	T. [unclear]	10/23/74
CUSTOMR.		

**MOORE INDUSTRIES INC.**  
 VAN NUYS ■ CA.

**ASSEMBLY, STANDARD SRT**  
 (ADDITIONAL PARTS LOCATION)

DWG. NO. **152-501-00** PG. 2 of 2 REV. **S**

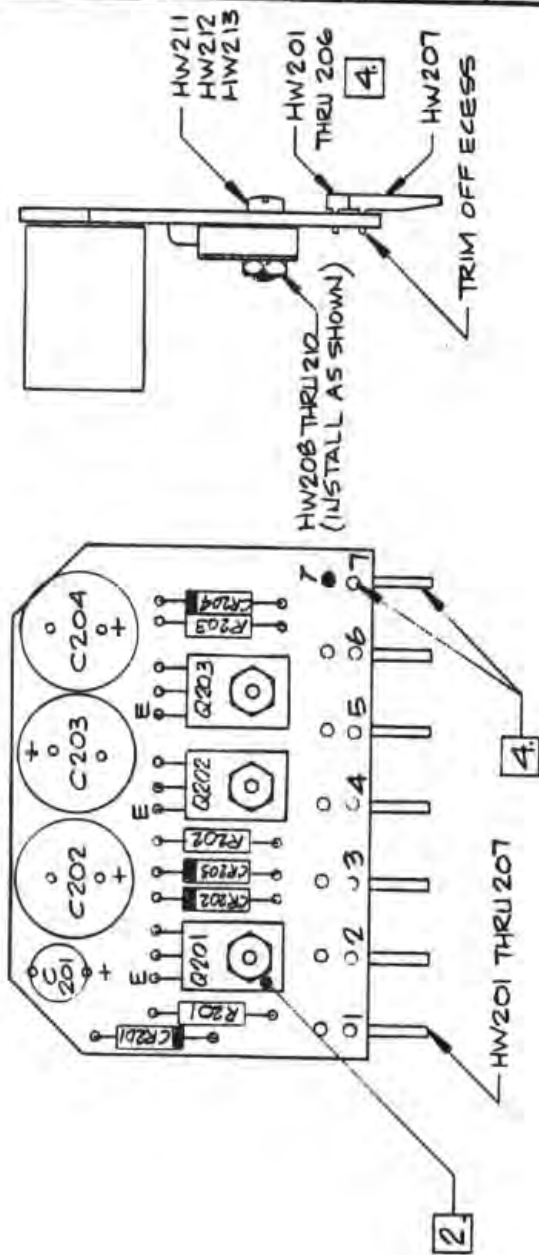

4. CUT HW207 BETWEEN TWO UPPER SOLDER PINS & REMOVE UPPER PORTION PRIOR TO INSERTING & SOLDERING IN BOTTOM HOLE. KEEP TOP HOLE FREE OF SOLDER.
  3. FOR SCHEMATIC SEE DRAWING: 152-401-00.
  2. METAL SIDE OF Q201, Q202 & Q203 TO FACE UP; (AWAY FROM BOARD).
  1. ALL LEADS MUST BE SOLDERED TO PADS.
- NOTES: UNLESS OTHERWISE SPECIFIED**

# RETURN PROCEDURES

## To return equipment to Moore Industries for repair, follow these four steps:

1. Call Moore Industries and request a Returned Material Authorization (RMA) number.

### Warranty Repair –

If you are unsure if your unit is still under warranty, we can use the unit's serial number to verify the warranty status for you over the phone. Be sure to include the RMA number on all documentation.

### Non-Warranty Repair –

If your unit is out of warranty, be prepared to give us a Purchase Order number when you call. In most cases, we will be able to quote you the repair costs at that time. The repair price you are quoted will be a "Not To Exceed" price, which means that the actual repair costs may be less than the quote. Be sure to include the RMA number on all documentation.

2. Provide us with the following documentation:
  - a) A note listing the symptoms that indicate the unit needs repair
  - b) Complete shipping information for return of the equipment after repair
  - c) The name and phone number of the person to contact if questions arise at the factory
3. Use sufficient packing material and carefully pack the equipment in a sturdy shipping container.
4. Ship the equipment to the Moore Industries location nearest you.

The returned equipment will be inspected and tested at the factory. A Moore Industries representative will contact the person designated on your documentation if more information is needed. The repaired equipment, or its replacement, will be returned to you in accordance with the shipping instructions furnished in your documentation.

### WARRANTY DISCLAIMER

THE COMPANY MAKES NO EXPRESS, IMPLIED OR STATUTORY WARRANTIES (INCLUDING ANY WARRANTY OF MERCHANTABILITY OR OF FITNESS FOR A PARTICULAR PURPOSE) WITH RESPECT TO ANY GOODS OR SERVICES SOLD BY THE COMPANY. THE COMPANY DISCLAIMS ALL WARRANTIES ARISING FROM ANY COURSE OF DEALING OR TRADE USAGE, AND ANY BUYER OF GOODS OR SERVICES FROM THE COMPANY ACKNOWLEDGES THAT THERE ARE NO WARRANTIES IMPLIED BY CUSTOM OR USAGE IN THE TRADE OF THE BUYER AND OF THE COMPANY, AND THAT ANY PRIOR DEALINGS OF THE BUYER WITH THE COMPANY DO NOT IMPLY THAT THE COMPANY WARRANTS THE GOODS OR SERVICES IN ANY WAY.

ANY BUYER OF GOODS OR SERVICES FROM THE COMPANY AGREES WITH THE COMPANY THAT THE SOLE AND EXCLUSIVE REMEDIES FOR BREACH OF ANY WARRANTY CONCERNING THE GOODS OR SERVICES SHALL BE FOR THE COMPANY, AT ITS OPTION, TO REPAIR OR REPLACE THE GOODS OR SERVICES OR REFUND THE PURCHASE PRICE. THE COMPANY SHALL IN NO EVENT BE LIABLE FOR ANY CONSEQUENTIAL OR INCIDENTAL DAMAGES EVEN IF THE COMPANY FAILS IN ANY ATTEMPT TO REMEDY DEFECTS IN THE GOODS OR SERVICES, BUT IN SUCH CASE THE BUYER SHALL BE ENTITLED TO NO MORE THAN A REFUND OF ALL MONIES PAID TO THE COMPANY BY THE BUYER FOR PURCHASE OF THE GOODS OR SERVICES.

ANY CAUSE OF ACTION FOR BREACH OF ANY WARRANTY BY THE COMPANY SHALL BE BARRED UNLESS THE COMPANY RECEIVES FROM THE BUYER A WRITTEN NOTICE OF THE ALLEGED DEFECT OR BREACH WITHIN TEN DAYS FROM THE EARLIEST DATE ON WHICH THE BUYER COULD REASONABLY HAVE DISCOVERED THE ALLEGED DEFECT OR BREACH, AND NO ACTION FOR THE BREACH OF ANY WARRANTY SHALL BE COMMENCED BY THE BUYER ANY LATER THAN TWELVE MONTHS FROM THE EARLIEST DATE ON WHICH THE BUYER COULD REASONABLY HAVE DISCOVERED THE ALLEGED DEFECT OR BREACH.

### RETURN POLICY

For a period of thirty-six (36) months from the date of shipment, and under normal conditions of use and service, Moore Industries ("The Company") will at its option replace, repair or refund the purchase price for any of its manufactured products found, upon return to the Company (transportation charges prepaid and otherwise in accordance with the return procedures established by The Company), to be defective in material or workmanship. This policy extends to the original Buyer only and not to Buyer's customers or the users of Buyer's products, unless Buyer is an engineering contractor in which case the policy shall extend to Buyer's immediate customer only. This policy shall not apply if the product has been subject to alteration, misuse, accident, neglect or improper application, installation, or operation. THE COMPANY SHALL IN NO EVENT BE LIABLE FOR ANY INCIDENTAL OR CONSEQUENTIAL DAMAGES.



**WORLDWIDE • www.miinet.com**

United States • info@miinet.com Tel: (818) 894-7111 • FAX: (818) 891-2816	Belgium • info@mooreind.be Tel: 03/448.10.18 • FAX: 03/440.17.97	China • sales@mooreind.sh.cn Tel: 86-21-62491499 • FAX: 86-21-62490635
Australia • sales@mooreind.com.au Tel: (02) 8536-7200 • FAX: (02) 9525-7296	The Netherlands • sales@mooreind.nl Tel: (0)344-617971 • FAX: (0)344-615920	United Kingdom • sales@mooreind.com Tel: 01293 514488 • FAX: 01293 536852